

sat-nms Antenna Step Track System

The **sat-nms** ACU adaptive step track system is an antenna manufacturer independent tracking system that can be easily connected to any satellite ground station antenna. The two core modules are:

- **sat-nms** ACU-ODM Tracking System
- **sat-nms** LBRX Beacon Receiver

The modular architecture and standard interfaces simplify new or retrofit integration. The **sat-nms** Antenna Control System is an economic alternative to the systems provided by antenna manufacturers. SatService GmbH provides upgrade kits for all the antenna types on the market and can also perform on-site system integration.

The **sat-nms** ACU-ODM outdoor module is the core module of a complete antenna step track system which tracks precisely any antenna size on the satellite. The software not only implements the standard step tracking mode but SatService has also implemented an improved Adaptive Tracking algorithm. The ACU records the tracked positions over several days and calculates based on this data a mathematical model which is used to predict the antenna position. This reduces the step track failure and provides continuous operation in case of a beacon receive failure.

In the Program Tracking Mode the antenna follows a path defined by a file which contains time stamped azimuth, elevation and polarization values, which usually has been calculated by an external software.

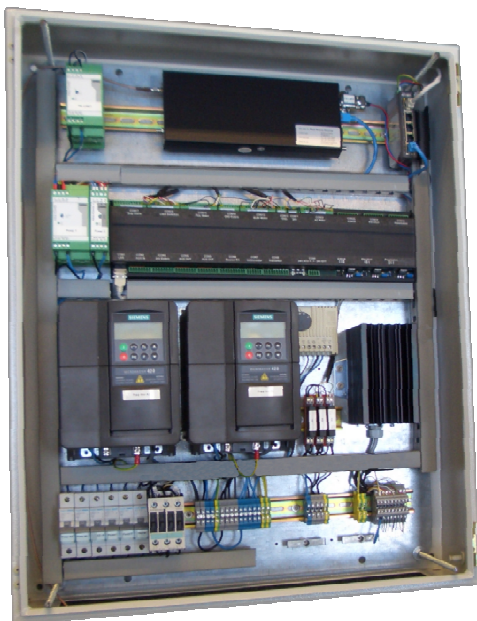

Key Features

- Adaptive Step Tracking with self-learning orbit model tracking algorithm
- Together with **sat-nms** LBRX a complete step-track system in cabinet at the antenna
- Web-based, user-friendly operator interface
- HTTP protocol for external M&C interface
- high sophisticated ACU-IDU Indoor Unit

Contact Information

SatService
Gesellschaft für Kommunikationssysteme mbH

Hardstrasse 9, D-78256 Steisslingen, Germany
phone +49 7738 97003, fax +49 7738 97005

e-mail info@sat-service.de

www.satnms.com, www.sat-service.de

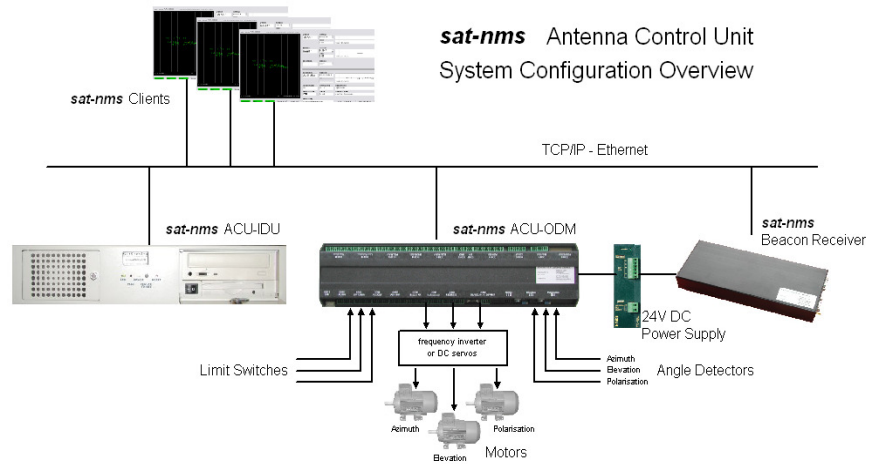

The DIN rail module provides all necessary interfaces to any antenna. Therefore, the **sat-nms** ACU-ODM can be very flexible adapted to any type of antenna as the motor controllers can be selected independent.

- Three motor controllers, like DC servos (for smaller antennas or frequency inverters, which are commonly used in larger antennas)
- Limit switches, Interlock and Motor-Off switches
- Angular detectors which measure the azimuth, elevation and polarization angle, three different daughter boards are available which cover most of the different angle detectors used in satellite ground stations:
 - Analog resolver, covering the existing antennas
 - Digital angle detectors with SSI interface
 - A/D interface to measure the voltage across a precision potentiometer

The DIN rail module is normally integrated in the ACU-ODU cabinet at the antenna mount, together with the **sat-nms** LBRX Beacon Receiver (also available as DIN rail module).

The **sat-nms** ACU-ODM module includes an integrated web server and provides its operator interface via web browser. The Ethernet is the main interface and the **sat-nms** ACU-ODM processor includes http, ftp and telnet services for remote diagnosis and support. The system is easy to maintain and all support can be performed remotely. Furthermore, the interface to high-level M&C systems or an ACU-IDU is provided via Ethernet and TCP/IP.

Technical Specification

Positioning / Tracking

| | |
|--|---|
| Position Encoding | Resolver, digital SSI and potentiometer, scalable per axis |
| Quantization Error | Resolver 16bit: 0,0055° SSI: 13bit: 0,044°, 16bit: 0,0055°, 17bit: 0,0028°, 19bit: 0,0007° |
| Display Position Resolution | 0,001° |
| Maximum travel rate of each antenna axis | 1%/sec |
| Interfaces to beacon receivers | sat-nms LBRX or analog voltage input for other vendors equipment |
| Analog voltage input | 0 to 10V |
| Option Tracking Accuracy | Encoder coupling and alignment error should not exceed 0.003° to achieve specified tracking accuracy. The influence of antenna structure thermal error is not considered. |
| In step track mode | Better than 10% of receive 3dB beam width (RMS). |
| In adaptive tracking mode | Better than 5% of receive 3dB beam width (RMS). |
| Position Encoding | 1 LSB of resolver / digital conversion |
| Operational Modes | Manuel Mode, Step Track, Adaptive Tracking takes into account last days history, Program Tracking based on time stamped file data |
| Number of Presets | 99 storage of ACU configuration (including LBRX beacon receiver settings) |

System Interfaces

| | |
|---|---|
| M&C interface | 10-Base-T, via HTTP GET requests |
| Operator access | With web browser |
| To M&C and ACU-IDU | Ethernet RJ45 or RS232 |
| To 6 limit switches | Opto-coupler input for azimuth, elevation and polarization |
| Interlock and motors-off switches | Opto-coupler input |
| 3 angular detectors | Resolver, SSI or A/D input |
| Motor driver interface (for frequency inverter, DC servos etc.) | Via opto coupler inputs and outputs: Motor on/off and direction, low and high speed selection, reset driver, driver fault |

Electrical and Mechanical Specification, Environmental Conditions

| | |
|---|---|
| Supply voltage | Any type of 230V AC mains voltage single or 3 phase |
| Temperature range | 5° to 50° C |
| Humidity | Up to 90% non condensing |
| Outdoor cabinet size (with rain canopy) | 610 x 795 x 235 mm (WxHxD) |

ACU Indoor Unit

The **sat-nms** ACU-IDU is for customers who want to have a more classic antenna step track system which also has an Indoor Unit. This ACU system does provide even more functionality, like data archiving, adaptive tracking, tracking on the basis of Intelsat data, two-line Kepler elements, graphical presentation of the angular and beacon level variation via time and other sophisticated features.

The **sat-nms** ACU-IDU is an industrial PC incorporating digital technology for accurate antenna tracking with high reliability, flexibility and a user-friendly operator interface. This system is ideally suited for all kind of satellite ground station antennas.

The screenshot displays the 'Antenna Control Unit ODM' web interface. The main section shows tracking data for a '1,8m Antenna':

| Parameter | Value |
|--------------|----------|
| Azimuth | 114.681° |
| Elevation | 46.844° |
| Polarization | -60.700° |

Below this, a table shows target values: Az. target value 114.686°, El. target value 46.845°, Pol. target value -60.300°. The status is 'MOVING'.

The ACU-IDU control panel includes a 'Step Move' section with directional buttons and a 'STOP' button. The main control area features a grid plot showing the antenna's path in green. To the right, various tracking parameters are listed:

- Target name: Telecom 2D
- Tracking mode: OFF
- Beacon level: -95.56 dBm (var 0.00 dB)
- Temperature: 42.7 °C
- ACU Faults: (empty)
- Tracking Faults: (empty)
- AZ Tracking State: M=NONE A=0% L=0%

The bottom section of the ACU-IDU interface shows detailed tracking parameters for 'ASTRA 19.2°E TP51':

- azimuth: 171.532° (target: 171.522°)
- elevation: 29.535° (target: 29.537°)
- polarization: 0.00° (target: 0.00°)
- beacon level: -70.93 dBm (threshold: -78.00 dBm)
- frequency: 11196.017 MHz (gain: -10 dB)
- bandwidth: 30 kHz (filter: 0.5 Hz)
- tracking mode: ADAPTIVE (interval: 600 sec)
- robot tracking: OFF (interval: 300 sec)
- operation state: ADAPTIVE (SLEEPING)